



M 130

DYNAMIC MICROPHONE

Order # 129.534

FEATURES

- Double ribbon microphone
- Consistent figure-eight polar pattern
- Superb transient response
- Balanced, uncoloured sound
- Compact design
- Characteristically warm and natural sound

APPLICATIONS

The M 130's unique double ribbon element has superb transient response, creating a highly detailed sound with unequalled accuracy and transparency. The bidirectional figure eight polar pattern effectively suppresses unwanted interference from the sides. The M 130's balanced, uncoloured sound handles a wide variety of applications. In conjunction with the hypercardioid M 160, the M 130 is ideal for creating an authentic stereo image through the use of the M-S (Mid-Side) technique.

The M 130 gives excellent results when the Mid-Side technique is used to record or broadcast a true stereo image. Its rugged design handles the demands of remote recording/broadcast sessions as easily as those of the studio. Alone, the M 130 allows the recording of background audience noise and concert hall "ambience" without unwanted resonances. In the recording studio it is effective with backing vocal groups, percussion and mounted toms. The M 130's crisply articulated, uncoloured sound is well suited to such demanding audiophile applications as digital and direct-to-disc recording.

TECHNICAL SPECIFICATIONS

Transducer type	Dynamic
Operating principle	Pressure gradient
Frequency response	40 - 18,000 Hz
Polar pattern	Hypercardioid
Rear attenuation at 1 kHz	> 25 dB at 110°
Open circuit voltage at 1 kHz (0 dB = 1 V/Pa)	1.0 mV/Pa $\hat{=}$ -60 dBV
Nominal impedance	200 Ω
Load impedance	\geq 1000 Ω
Diaphragm	Pure aluminium
Case/finish	Brass
Connector	3-pin XLR male
Dimensions	Length: 128 mm Shaft diameter: 23 mm Head diameter: 38.5 mm
Weight without cable	150 g

Germany
Theresienstr. 8
74072 Heilbronn
Tel. (0 71 31) 6 17-0
Fax (0 71 31) 6 17-224
E-mail: info@beyerdynamic.de
Internet: www.beyerdynamic.de

United States
56 Central Ave.
Farmingdale, NY 11735
Tel. (631) 293-3200
Fax (631) 293-3288
E-mail: salesUSA@beyerdynamic.com
Internet: www.beyerdynamic.de

Great Britain
17 Albert Drive
Burgess Hill RH15 9TN
Tel. (01444) 258 258
Fax (01444) 258 444
E-mail: sales@beyerdynamic.co.uk
Internet: www.beyerdynamic.de

beyerdynamic

FREQUENCY RESPONSE & POLAR PATTERN

This frequency response curve (measuring tolerance ± 2.5 dB) and polar pattern correspond to a typical production sample for this microphone.

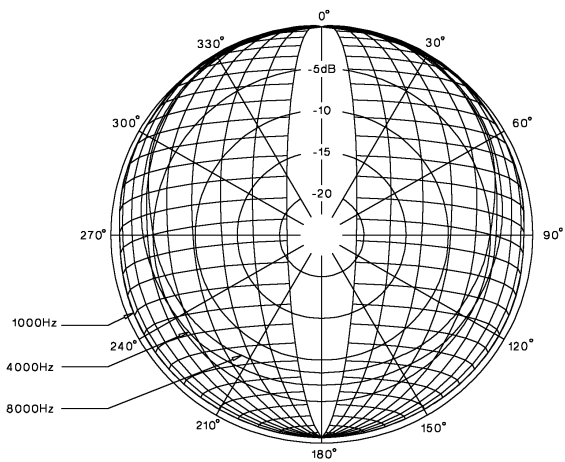
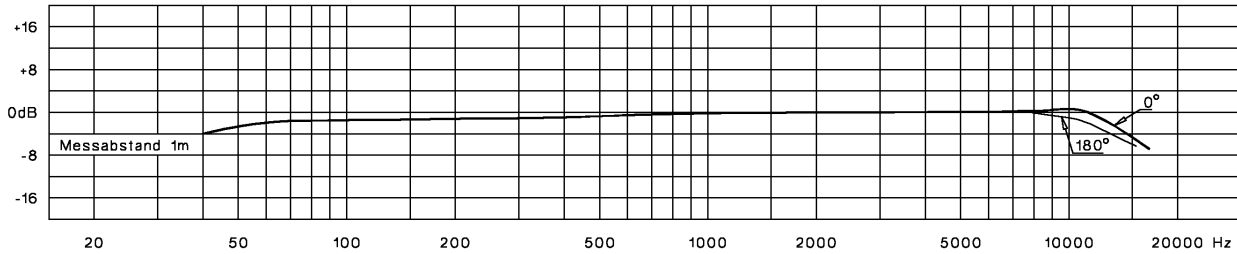

WIRING DIAGRAM

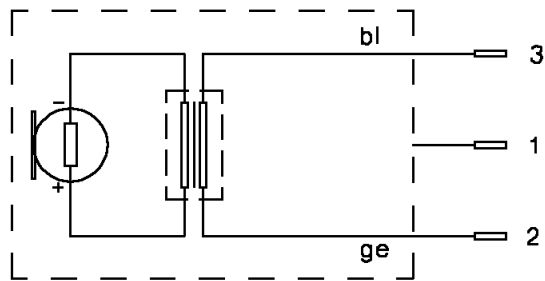

SUPPLIED ACCESSORIES

- Black, padded protective zipper bag
- MKV 8 Microphone clamp with 3/8" internal thread, for shaft diameters of 22 - 32 mm. Order # 407.216

OPTIONAL ACCESSORIES

- Highly flexible cables with industry standard jack and/or XLR connectors
- MKV 6 Microphone clamp (clothes peg style clip) for shaft diameters of 19 - 32 mm. Order # 407.208
- GST 400 Microphone stand, 3/8", height 0.90 - 1.65 m, with G 400 boom Order # 421.308
- GST 500 Microphone stand, 3/8", height 0.85 - 1.60 m, with telescopic G 500 boom Order # 406.252
- PS 260 Popscreen, charcoal-grey. Order # 133.604
- WS 260 Windscreen, charcoal-grey Order # 111.309